

## HELICAL ISOLATORS - HM08250 SERIES

### 1/4" DIA CABLE

EVANS Part Number	Dimensions(in.)		Compression		Shear & Roll		45° Compression/Roll	
	H	O.D.	Avg. Rate(lb/in)	Max Deflection(in)	Avg. Rate(lb/in)	Max Deflection(in)	Avg. Rate(lb/in)	Max Deflection(in)
HM08250-1	1.90	2.20	1033	0.6	516	0.8	300	1.5
HM08250-2	2.13	2.50	623	0.8	323	1.0	182	1.8
HM08250-3	2.31	2.80	423	1.0	277	1.3	122	2.2
HM08250-4	2.50	3.13	304	1.1	192	1.6	96	2.3
HM08250-5	2.50	3.50	234	1.3	174	1.7	92	2.5
HM08250-6	2.63	3.75	181	1.5	124	1.9	76	2.7
HM08250-7	2.63	3.95	159	1.5	110	2.0	75	2.8
HM08250-8	3.25	4.25	100	2.0	67	2.2	39	3.0

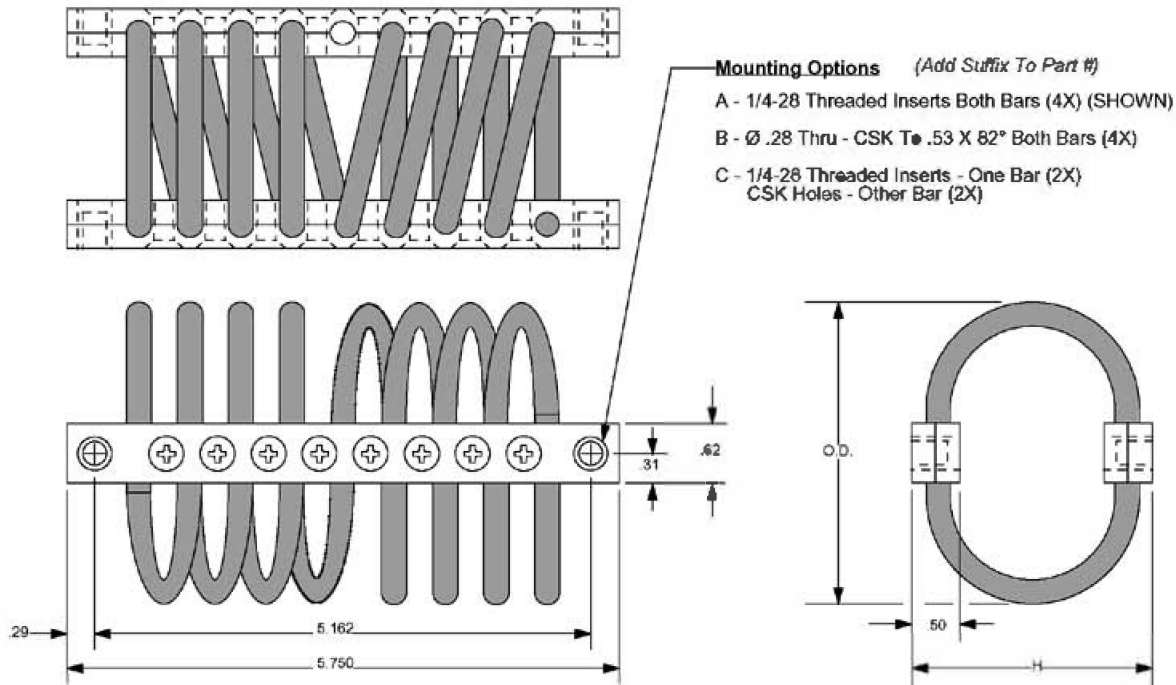

**REVISION 2  
REDRAWN NOVEMBER 18, 1997**

#### SPECIFICATIONS

CABLE: Stainless Steel per MIL-W-83420  
 RETAINING BARS: Aluminum Alloy - 6061-T6 - Iridited per MIL-C-5541  
 RETAINING SCREWS: Alloy Steel - Cadmium Plated per QQ-P-416 or Stainless Steel

*See other side for force-deflection curves.*

# HM08250 SERIES

## COMPRESSION

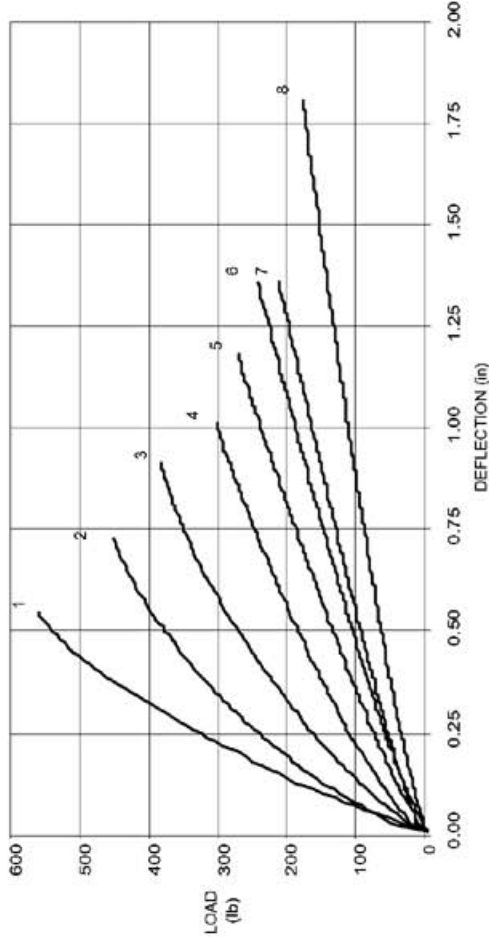

## SHEAR

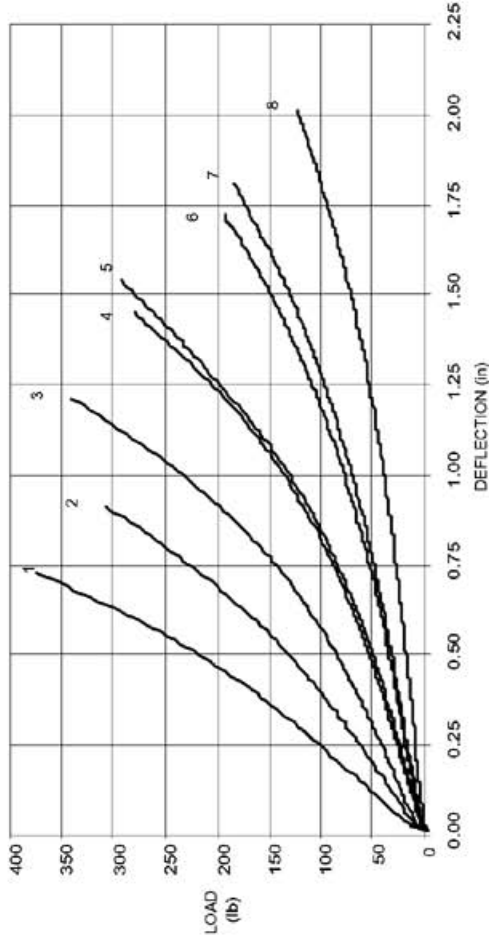

## 45° COMPRESSION/ROLL

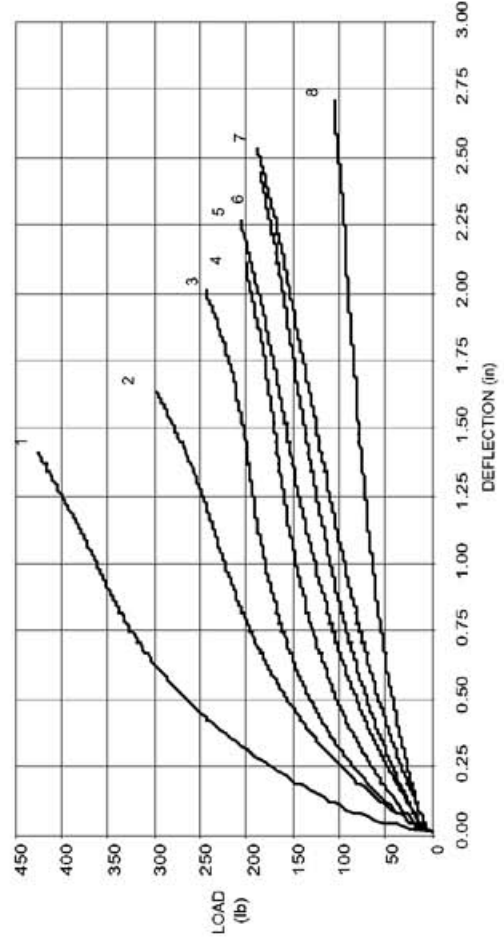

## ROLL

