



**Quality, reliability and a reasonable price.**

Our reels feature totally enclosed, gasketed spring rewind mechanisms for the ultimate in protection from the elements. When paying out cable, a sturdy latching system holds the cable at the desired length. A gentle tug on the cable releases the latch, and the cable retracts back onto the reel.

Reel construction is of galvanized/zinc plated steel with a durable baked enamel finish. All bearing surfaces are permanently lubricated. Stainless steel springs are available when specified. Various combinations of cable, end fittings and color are available to custom tailor a reel to your specific requirements!

## STANDARD MODELS

<b>DMI-50CC</b>	<b>50' Cable Extension</b>	<b>3/32" dia. 7x7 Stainless cable, yellow Hytrel jacket/100 amp copper clamp</b>
<b>DMI-75CC</b>	<b>75' Cable Extension</b>	<b>3/32" dia. 7x7 Stainless cable, yellow Hytrel jacket/100 amp copper clamp</b>
<b>DMI-100CC</b>	<b>100' Cable Extension</b>	<b>3/32" dia. 7x19 Stainless cable, non-jacketed/100 amp copper clamp</b>

### Cable Options

3/32" 7x19 Stainless steel cable, non-jacketed  
 3/32" 7x7 Galvanized steel, clear PVC jacket  
 3/32" dia. 7x7 Stainless cable, yellow Hytrel jacket  
 Wye Branch cable assemblies made to your requirements.

### Cable Clamp and Plug Options

100 Amp Mueller Copper Clamp #21C (shown above)  
 100 Amp Mueller 11A Extra Large Clamp  
 Military Style Plug MIL-C 83413/4  
 Military Style Clamp MIL-C 83413/7

All of our reel components are treated for corrosion resistance. Exterior can be painted green, red, or yellow to your specifications. Baked enamel green is standard.

**Military Specification:** A-A-50696  
**Electrical Resistance:** 10 ohms max. (clamp to mounting base).  
**Life Cycle:** Tested to 5,000 cycles (full extension and retraction).  
**Operating Temperature Range:** -65° F to 125° F  
**Storage Temperature Range:** -80° F to 160° F

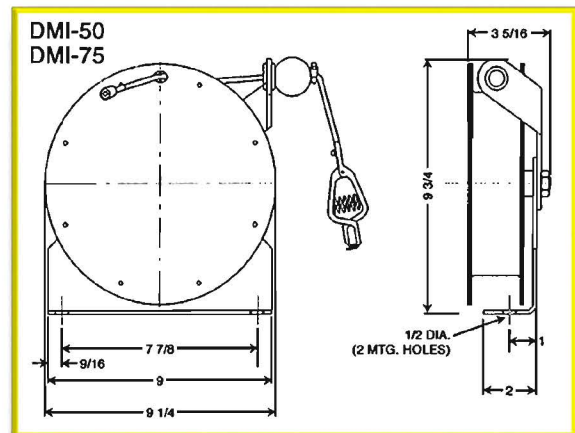

# Delmaco Manufacturing, Inc.

21424 Cedar Creek Ave.  
 Georgetown, DE 19947-6305

sales@delmacomfg.com  
 www.delmacomfg.com  
 phone: 302-521-8888  
 fax: 302-856-6347